



SINCE 1976

# SHOWFOU PUMP

## SHOWFOU

**MCP TYPE - VOLUTE PUMP for irrigation**

**SP TYPE - TURBINE PUMP**

**SPM TYPE - MULTISTAGE TURBINE PUMP**

**CV TYPE - VOLUTE PUMP**

**for industrial & cooling tower use**



標檢局

ISO-9001/CNS12681



**MCP** 2HP ~ 3HP



**SP** 1/2HP ~ 3HP

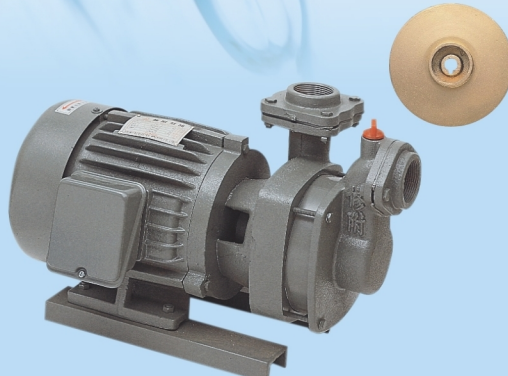

**SPM** 2HP ~ 5HP



**CV** 1/2HP ~ 100HP

**MCP**  
灌溉用渦流式幫浦

**SP**  
渦流式幫浦

**SPM**  
多段式渦輪幫浦

**CV**  
渦輪式幫浦

# MCP 灌溉用渦流式幫浦

## Volute Pump (for irrigation)

1HP x 2"



1.5HP x 2"



2HP x 3"  
3HP x 4"



### CONSTRUCTIONS: MCP(2HP,3HP)

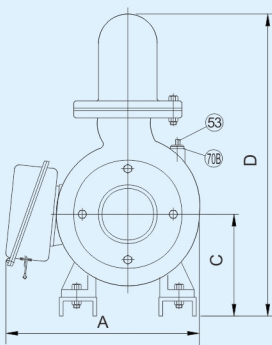
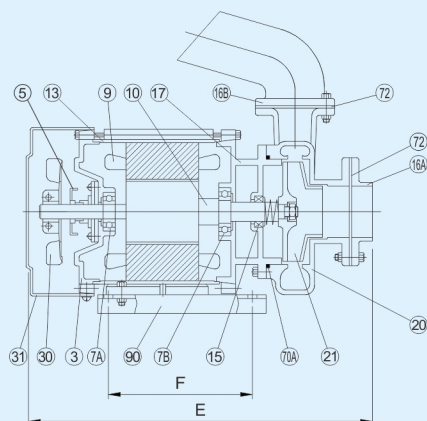

NO.	PARTS LIST	零件名稱	MATERIAL	材質
3	Motor Head Cover	馬達上蓋	Cast iron	鑄鐵
5	Centrifugal Switch	離心開關		
7A	Bearing (Upper)	上軸承		
7B	Bearing (Lower)	下軸承		
9	Coil	馬達線圈		
10	Shaft	主軸	SUS 304	不銹鋼
13	Motor Casing	馬達中框	Cast iron	鑄鐵
15	Mechanical Seal	機械軸封	Ceramic Carbon	陶瓷 碳精
16A	Flange Setter	有牙 法蘭套	Cast iron	鑄鐵
16B	Flange Setter	無牙 法蘭套	Cast iron	鑄鐵
17	Motor Lower Cover	馬達下蓋	Cast iron	鑄鐵
20	Pump Casing	水機	Cast iron	鑄鐵
21	Impeller	水葉	Bronze	青銅
30	Cooling Fan	風葉	Plastic	塑膠
31	Fan Cover	風葉蓋	Steel	鐵
53	Plug	塞頭	Plastic	塑膠
70A	O-ring	圓形防洩圈	NBR	丁腈橡膠
70B	O-ring	圓形防洩圈	NBR	丁腈橡膠
72	Outlet Rubber	出口徑橡皮	Rubber	橡膠
90	Support	馬達腳座	Plastic & Steel	塑膠&鐵

### PERFORMANCE CURVE

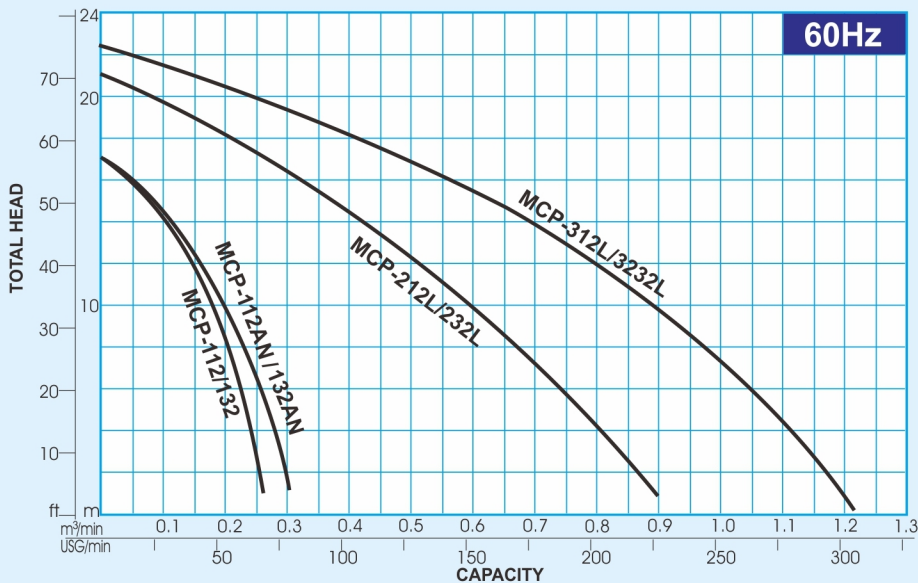
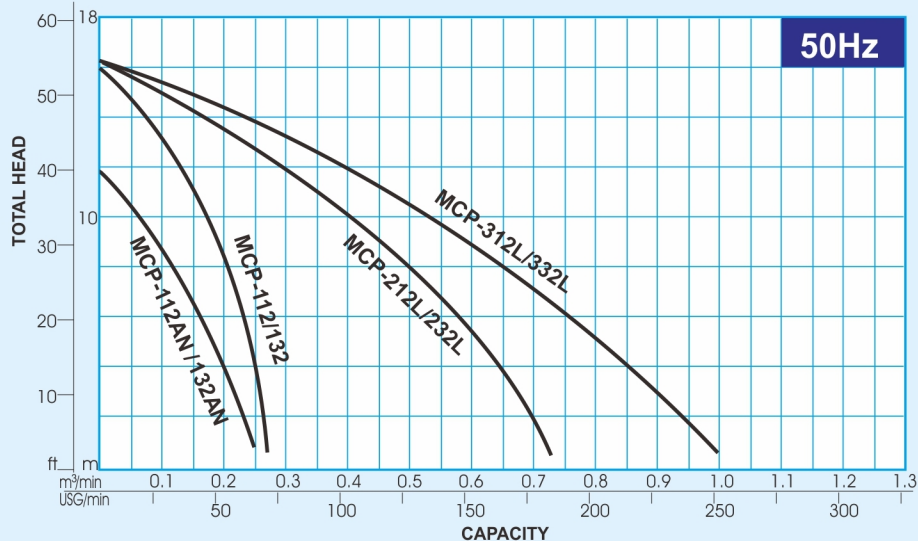

### SPECIFICATIONS:

### DIMENSIONS:

形式	電動機 MOTOR				PUMP		50Hz		60Hz		重量 Wt.	尺寸 SIZE					
	馬力 Power	相數 Phase	電壓 Volt	口徑 Disch. Dia.	最高揚程 Max. Head	最高水量 Max. Flow	最高揚程 Max. Head	最高水量 Max. Flow	mm	mm		mm	mm	mm	mm	mm	
TYPE	HP	kW	PH	V	inch	mm	M	m³/min	M	m³/min	kg	A	B	C	D	E	F
MCP-112AN	1	0.75	1	200-240	2	50	12	0.25	17	0.3	38	260	34	204	303	465	
MCP-132AN			3	220-480								260	34	204	303	465	
MCP-112	1.5	1.1	1	200-240	2	50	16	0.26	17	0.26	19.5	250	70	105	201	364	175
MCP-132			3	220-480								250	70	105	201	364	175
MCP-212L	2	1.5	1	200-240	3	80	16	0.7	21	0.9	46	290		117	448	545	250
MCP-232L			3	220-480								290		117	448	545	250
MCP-312L	3	2.2	1	200-240	4	100	15	1.0	22	1.2	54	322		138	503	582	250
MCP-332L			3	220-480								322		138	503	582	250

# SP 渦輪式幫浦 Turbine Pump



1/2HP ~ 3HP



## CONSTRUCTIONS:

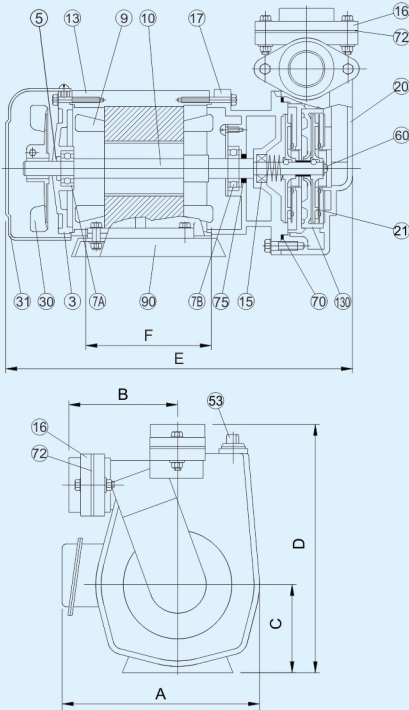

NO.	PARTS LIST	零件名稱	MATERIAL	材質
3	Motor Head Cover	馬達上蓋	Cast iron	鑄鐵
5	Centrifugal Switch	離心開關		
7A	Bearing (Upper)	上軸承		
7B	Bearing (Lower)	下軸承		
9	Coil	馬達線圈		
10	Shaft	主軸	SUS 304	不銹鋼
13	Motor Casing	馬達中框	Cast iron	鑄鐵
15	Mechanical Seal	機械軸封	Ceramic Carbon	陶瓷 碳精
16	Flange Setter	法蘭透	Cast iron	鑄鐵
17	Motor Lower Cover	馬達下蓋	Cast iron	鑄鐵
20	Pump Casing	水機	Cast iron	鑄鐵
21	Impeller	水葉	Bronze	青銅
30	Cooling Fan	風葉	Plastic	塑膠
31	Fan Cover	風葉蓋	Steel	鐵
53	Plug	塞頭	Plastic	塑膠
60	Bolt	公頭螺絲	Steel	鐵
70	O-ring	圓形防洩圈	NBR	丁腈橡膠
72	Outlet Rubber	出口徑橡皮	Rubber	橡膠
75	Shaft Rubber	心軸套橡皮		
90	Support	馬達腳座	Plastic & Steel	塑膠&鐵
130	Diffuser	切水盤	Cast iron & Plastic	鑄鐵&塑膠

## PERFORMANCE CURVE

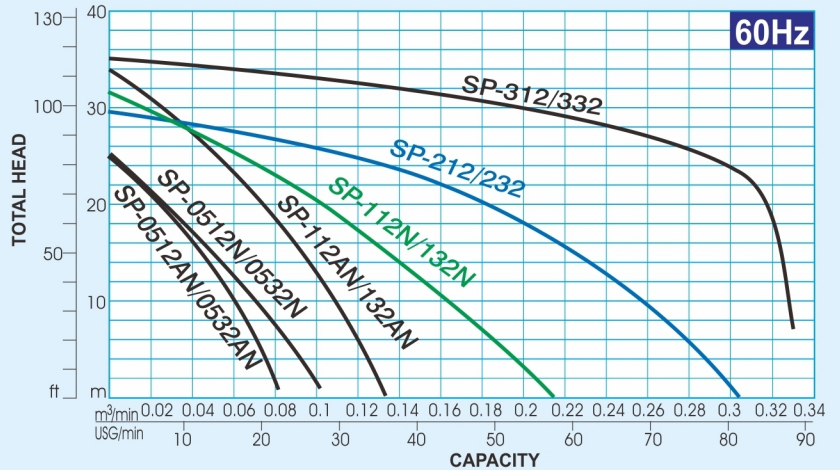
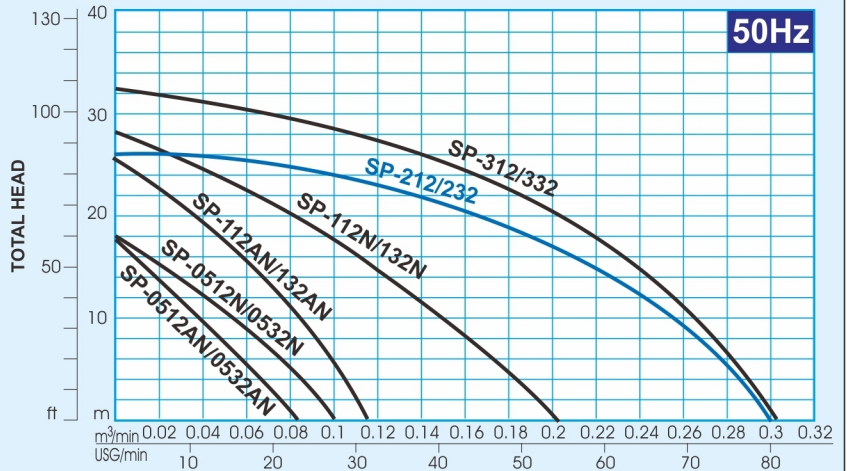

## SPECIFICATIONS:

形式 TYPE	電動機 MOTOR			PUMP 口徑 Disch. Dia.	50Hz		60Hz		重量 Wt. kg	尺寸 SIZE							
	馬力 Power HP	相數 Phase PH	電壓 Volt V		最高揚程 Max. Head M	最高水量 Max. Flow m³/min	最高揚程 Max. Head M	最高水量 Max. Flow m³/min		A mm	B mm	C mm	D mm	E mm	F mm		
SP-0512AN	1/2	0.4	1	200-240	3/4	20	18	0.08	25	0.09	16	211	111	82	221	305	175
SP-0532AN			3	220-480													
SP-0512N			1	200-240													
SP-0532N			3	220-480													
SP-112AN	1	0.75	1	200-240	1	25	25	0.11	34	0.13	24	225	111	86	246	342	175
SP-132AN			3	220-480													
SP-112N	1.5	1.1	1	200-240	1.5	40	28	0.20	32	0.21	28	228	107	106	276	393	200
SP-132N			3	220-480													
SP-212	2	1.5	1	200-240	2	50	26	0.3	30	0.3	45	289	93	125	334	445	
SP-232			3	220-480													
SP-312	3	2.2	1	200-240	2	50	32	0.3	35	0.33	54	292	181	138	342	456	
SP-332			3	220-480													

## DIMENSIONS:

# SPM 多段式渦輪幫浦

## Multi-Stage Turbine Pump

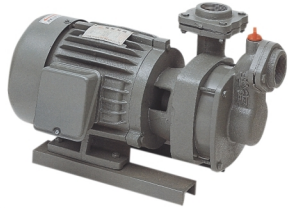

2HP ~ 5HP



### CONSTRUCTIONS:

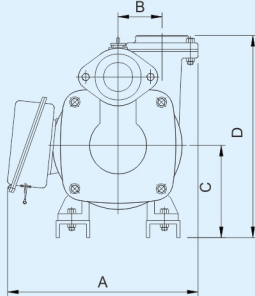
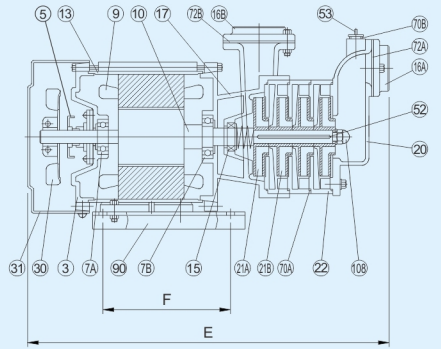

週率 Hz	馬力 HP	水葉段數 No. of impeller
60	2,3	3
60	5	4
50	2,3,5	4

NO.	PARTS LIST	零件名稱	MATERIAL	材質
3	Motor Head Cover	馬達上蓋	Cast iron	鑄鐵
5	Centrifugal Switch	離心開關		
7A	Bearing (Upper)	上軸承		
7B	Bearing (Lower)	下軸承		
9	Coil	馬達線圈		
10	Shaft	主軸	SUS 304	不銹鋼
13	Motor Casing	馬達中框	Cast iron	鑄鐵
15	Mechanical Seal	機械軸封	Ceramic Carbon	陶瓷 碳精
16A	Flange Setter	有牙 法蘭套	Cast iron	鑄鐵
16B	Flange Setter	無牙 法蘭套	Cast iron	鑄鐵
17	Motor Lower Cover	馬達下蓋	Cast iron	鑄鐵
20	Pump Casing	水機	Cast iron	鑄鐵
21A	Impeller	水葉 (小)	Bronze	青銅
21B	Impeller	水葉	Bronze	青銅
22	Suction cover	吸水盤	Cast iron	鑄鐵
30	Cooling Fan	風葉	Plastic	塑膠
31	Fan Cover	風葉蓋	Steel	鐵
52	Key	鍵	Steel	鐵
53	Plug	塞頭	Plastic	塑膠
70A	O-ring	圓形防洩圈	NBR	丁腈橡膠
70B	O-ring	圓形防洩圈	NBR	丁腈橡膠
72A	Outlet Rubber	橢圓 出口徑橡皮	Rubber	橡膠
72B	Outlet Rubber	方形 出口徑橡皮	Rubber	橡膠
90	Support	馬達腳座	Steel	塑膠&鐵
108	Nut	袋帽	Bronze	青銅

### PERFORMANCE CURVE

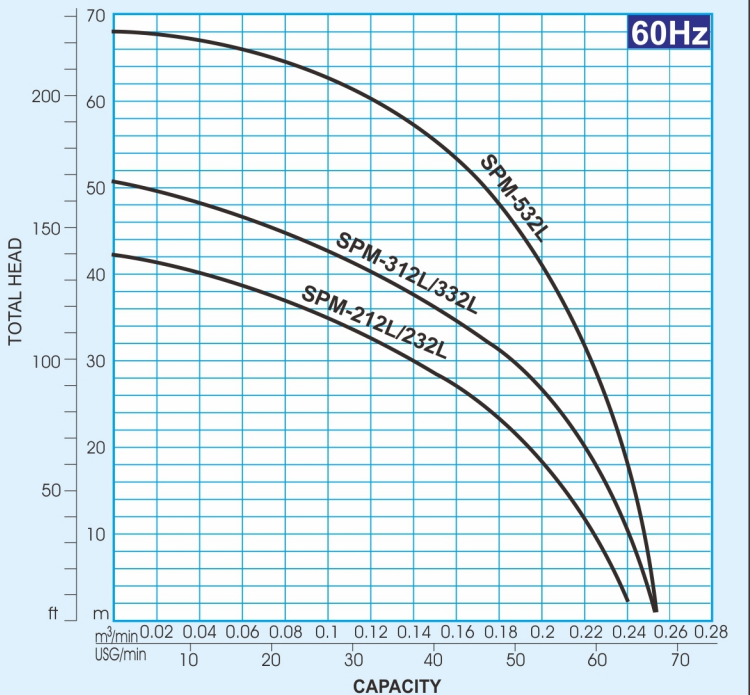
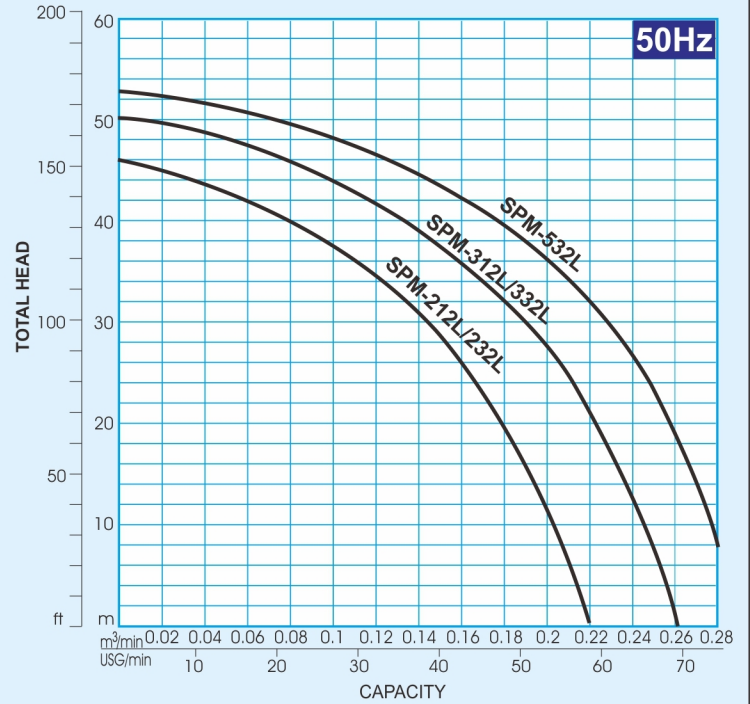

### SPECIFICATIONS:

形式 TYPE	電動機 MOTOR			PUMP	50Hz		60Hz		重量 Wt.	尺寸 SIZE							
	馬力 Power HP	相數 Phase PH	電壓 Volt V		口徑 Disch. Dia. inch	最高揚程 Max. Head M	最高水量 Max. Flow m³/min	最高揚程 Max. Head M		最高水量 Max. Flow m³/min	A	B	C	D	E	F	
	mm	mm	mm	mm	M	m³/min	M	m³/min	kG	mm	mm	mm	mm	mm	mm		
SPM-212L	2	1.5	1	200-240	1.5	40	46	0.22	42	0.24	40	256	68	125	281	482	200
SPM-232L			3	220-480								256	68	125	281	464	200
SPM-312L	3	2.2	1	200-240	2	50	50	0.26	50	0.26	46	265	65	124	281	505	245
SPM-332L			3	220-480								253	65	124	281	486	238
SPM-532L	5	3.7	3	220-480	2	50	53	0.28	68	0.25	47	255	78	124	281	532	245

### DIMENSIONS:

# CV 渦流式幫浦 Volute Pump



1/2HP ~ 100HP



## CONSTRUCTIONS:

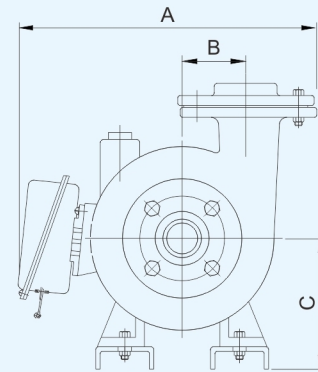
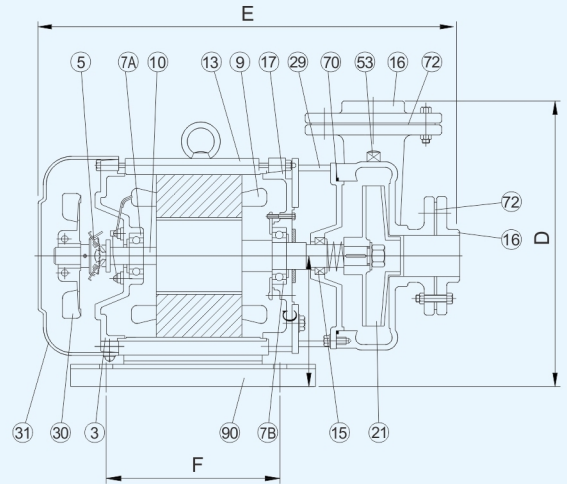

NO.	PARTS LIST	零件名稱	MATERIAL	材質
3	Motor Head Cover	馬達上蓋	Cast iron	鑄鐵
5	Centrifugal Switch	離心開關		
7A	Bearing (Upper)	上軸承		
7B	Bearing (Lower)	下軸承		
9	Coil	馬達線圈		
10	Shaft	主軸	SUS 304	不銹鋼
13	Motor Casing	馬達中框	Cast iron	鑄鐵
15	Mechanical Seal	機械軸封	Ceramic+Carbon	陶瓷+碳精
16	Flange Setter	法蘭透	Cast iron	鑄鐵
17	Motor Lower Cover	馬達下蓋	Cast iron	鑄鐵
21	Impeller	水葉	Bronze	青銅
29	Pump Bracket	中軸座	Cast iron	鑄鐵
30	Cooling Fan	風葉	Plastic	塑膠
31	Fan Cover	風葉蓋	Steel	鐵
53	Plug	塞頭	FCD	鑄鐵
70	O-ring	圓形防洩圈	NBR	丁腈橡膠
72	Outlet Rubber	出口徑橡皮	Rubber	橡膠
90	Support	馬達腳座	Plastic & Steel	塑膠&鐵

## SPECIFICATIONS:

型式 TYPE	電動機 MOTOR				PUMP 口徑 Disch.Dia. inch mm	50Hz		60Hz		重量 Wt. kg	尺寸 SIZE							
	馬力 Power HP kW	相數 Phase PH	電壓 Volt V	極數 Poles P		最高揚程 Max. Head M	最大水量 Max. Flow m <sup>3</sup> /min	最高揚程 Max. Head M	最大水量 Max. Flow m <sup>3</sup> /min		A mm	B mm	C mm	D mm	E mm	F mm		
	CV-0512	1/2	0.4	1		200-240	2	1	25		13	0.13	19	0.13	20	275	80	80
CV-0532	3			220-480	275	80				80						212	327	175
CV-112	1	0.75	1	200-240	2	1.5	40	16	0.18	20	0.18	23	293	80	110	249	359	200
CV-132			3	220-480									293	80	110	249	359	200
CV-212	2	1.5	1	200-240	2	2	50	18	0.30	24	0.30	30	323	110	120	286	417	200
CV-232			3	220-480									323	110	120	286	417	200
CV-332	3	2.2	3	220-480	2	2.5	65	23	0.6	26	0.6	35	323	110	120	286	417	200
CV-532	5	3.7	3	220-480	2	3	80	24	0.9	28	0.9	60	367	110	140	317	512	260
CV-732	7.5	5.5	3	220-480	2	4	100	24	1.4	26	1.4	85	425	125	158	367	567	280
CV-1032	10	7.5	3	220-480	2	4	100	31	1.4	34	1.4	90	425	125	158	367	567	280
CV-1532	15	11	3	220-480	2	4	100	32	2.0	36	2.0	110	440	125	158	372	661	280
CV-2032-4	20	15	3	220-480	4	6	150	23	4.6	30	3.5	228	600	185	235	500	805	420
CV-2532-4	25	18	3	220-480	4	6	150	29	5.2	32	5.0	305						
CV-3032-4	30	22	3	220-480	4	6	150	28.5	4.6	26	6.0	326						
CV-4032-4	40	30	3	220-480	4	8	200	28	6.0	30	7.3	432						
CV-5032-4	50	37	3	220-480	4	8	200	30	8.0	30	8.0	504						
CV-6032-4	60	45	3	220-480	4	8	200	32	8.6	32	8.6	573						
CV-7032-4	75	60	3	220-480	4	8	200	34	8.9	34	8.9	636						
CV-10032-4	100	75	3	220-480	4	10	250	39	13.9	39	13.9	716						

Note: The further details about CV type over 20 HP will be provided upon request.

■ PERFORMANCE CURVE

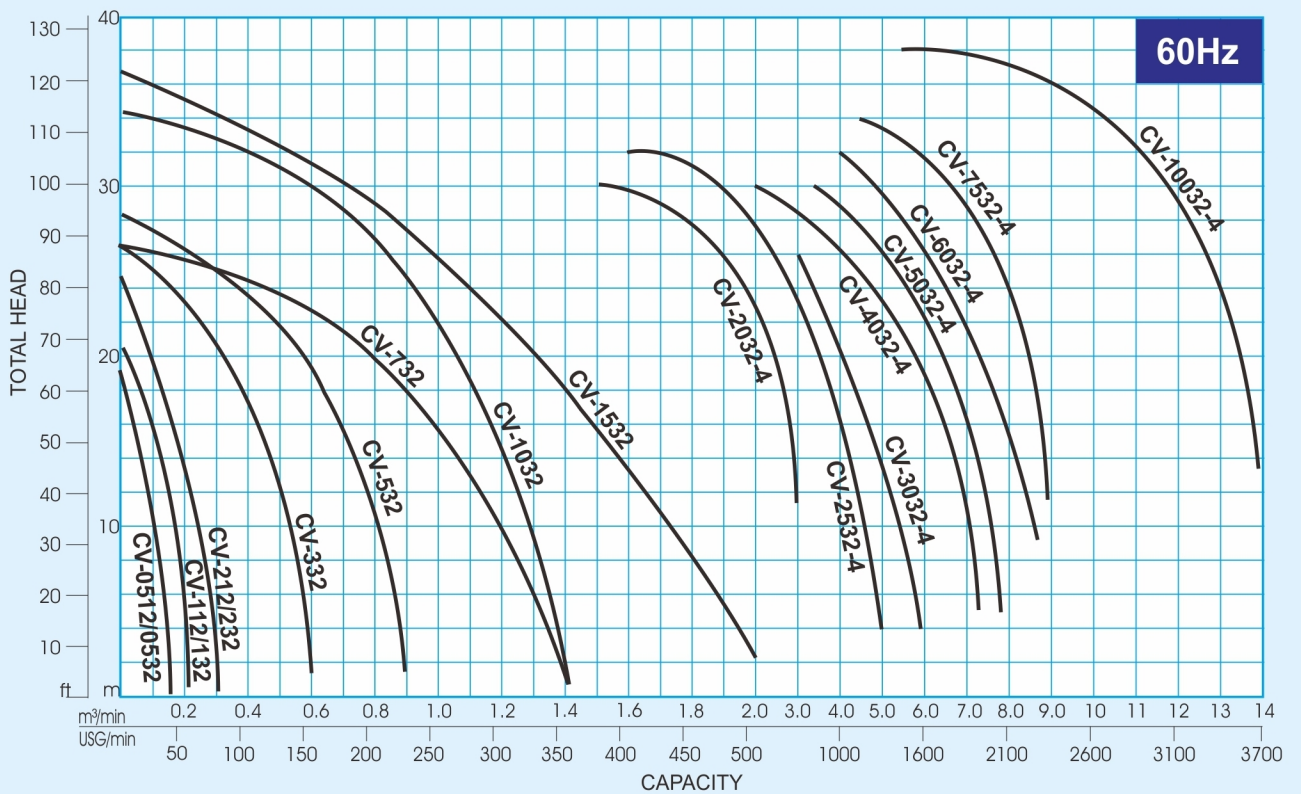
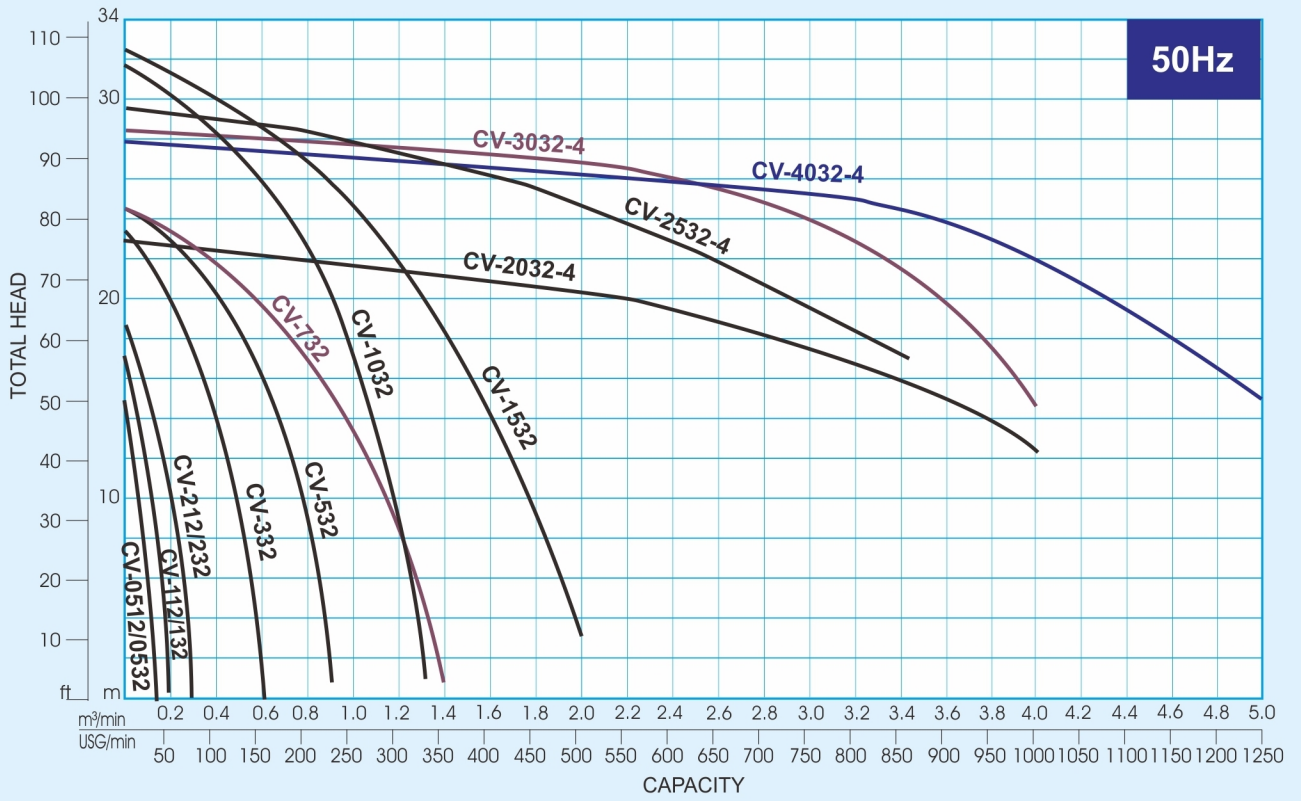

SHOWFOU ELECTRIC MACHINE CO., LTD.  
www.pompacelup.id

修耐電機股份有限公司  
高雄市岡山區(82059)本工路66號

0812-9876-6766

All specifications subject to change without notice.